

# Process displays electronic

## Analogue measured value input, 2 limits

### Large 14 mm display LED, 6-digits, programmable

#### PCD41



PCD41 - Process display

#### Technical data - electrical ratings

Voltage supply	115/230 VAC $\pm 10\%$ (50/60 Hz) 24/48 VAC $\pm 10\%$ (50/60 Hz) 12...30 VDC
Power consumption	6 VA, 4 W
Sensor supply	12...26 VDC / max. 80 mA
Display	LED, 7-segment display
Number of digits	6-digits
Digit height	14 mm
Function	Digital display of 1 analogue measured value
Measuring principle	Analogue resolution 12 bit
Input logic	PNP
Control inputs	2 Inputs
Control functions	Hold, Reset, Keylock, etc.
Data memory	>10 years in EEPROM
Analogue input	0(2)...10 V, 0(4)...20 mA Resolution 12 bit Temp. coeff. typ. $\pm 20$ ppm/ $^{\circ}$ C
Outputs relay	Normally open or closed, programmable
Interfaces	RS232, RS422, RS485
Standard DIN EN 61010-1	Protection class II Overvoltage category II Pollution degree 2
Emitted interference	DIN EN 61000-6-3
Interference immunity	DIN EN 61000-6-2
Programmable parameters	2 limits, analogue input Control inputs Calculating functions Offset (maximum and minimum analogue limit)
Approvals	UL/cUL, CE conform

#### Features

- Process display
- Display 6-digits
- Connection: One-channel analogue sensor
- Two limits as relay output
- With peak value memory
- Interface RS232 or RS422/RS485

#### Description

PCD41 is a display for measured values which signals are available as voltage or DC current. The operator is aligning the display by means of the front keypad. Two optional limits "P1" and "P2" that can be assigned at will allow production process control. Furthermore there is an electronic peak value memory (slave pointer).

#### Technical data - mechanical design

Operating temperature	0...+50 $^{\circ}$ C
Storing temperature	-20...+70 $^{\circ}$ C
Relative humidity	80 % non-condensing
Core cross-section	1.5 mm <sup>2</sup>
Protection DIN EN 60529	IP 65 face with seal
Operation / keypad	Membrane with softkeys
Housing type	Housing for control panel installation
Dimensions W x H x L	96 x 48 x 124 mm
Cutout dimensions	94 x 45 mm (+0.6)
Installation depth	123.75 mm
Mounting	Front panel installation by clip frame
Weight approx.	350 g (AC), 250 g (DC)
Material	Housing: Makrolon 6485 (PC)

# Process displays electronic

## Analogue measured value input, 2 limits

### Large 14 mm display LED, 6-digits, programmable

PCD41

#### Part number

PCD41. PX01

#### Voltage supply

- 1 24 / 48 VAC
- 2 115 / 230 VAC
- 3 12...30 VDC

#### Inputs / outputs

- 0 0...10 V / without limits
- 1 0...20 mA / without limits
- 2 0...10 V / with limits
- 3 0...20 mA / with limits

#### Interface

- 0 Without interface
- 1 RS422 / RS485
- 2 RS232

#### Block circuit diagram

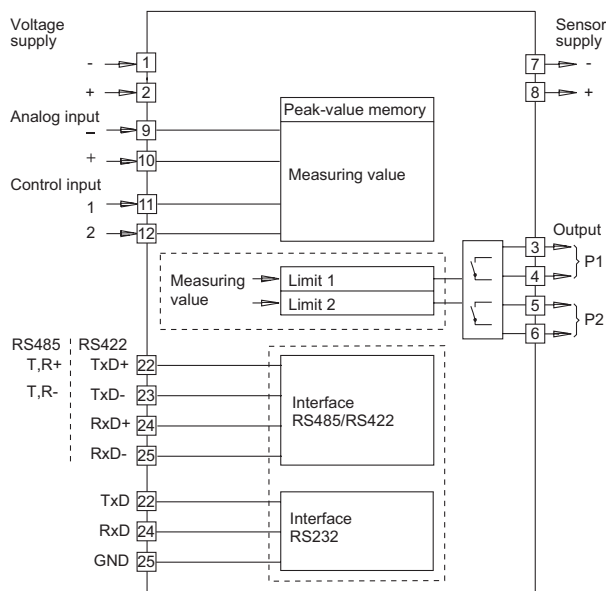

#### Connection diagram

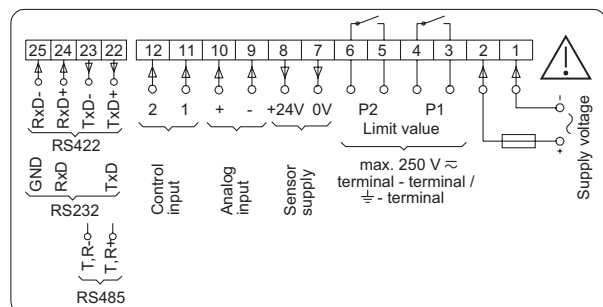

#### Trigger level

Comparator inputs	Input circuit
Control inputs	PNP-logic
Input level	Programmable
Input level Low	0...2 VDC
Input level High	3...40 VDC
Input resistance	3 kΩ
Relay outputs	Output circuit
Switching voltage max.	250 VAC / 110 VDC
Switching current max.	1 A
Switching capacity max.	150 VA / 30 W
Relay responding time	5 ms

#### Dimensions

