

Memory controllers

Manual format alignment

Display LCD two lines, interface RS485

N 240



N 240 - Manual format alignment

Features

- Memory controller for manual format alignment
- Display: LCD backlit, two lines alphanumeric, multilingual
- Programming and memory unit
- Memory for 100 formats with max. 32 position displays
- Interface RS485

Technical data - electrical ratings

Voltage supply	85...265 VAC (50/60 Hz)
Current consumption	≤1000 mA
Reverse polarity protection	No
Sensor supply	24 VDC ±10 % / <0.9 A
Display	LCD-TFT, 2-lines, backlit, alphanumeric
Function	User menu, multilingual Memory unit for 100 format profiles Programming of max. 32 SPA SPA zero point alignment Start position for target display N 155
Keylock	Secured by code
Control output relay	Shafts in position
Switching capacity relay	100 VA / 30 W
Switching current relay	1 A
Switching voltage relay	265 VAC
Data memory	>10 years in EEPROM
Interface	RS485 (ASCII protocol)
Programmable parameters	Language selection
Standard DIN EN 61010-1	Protection class II Overvoltage category II Pollution degree 2
Emitted interference	DIN EN 61000-6-3
Interference immunity	DIN EN 61000-6-2
Approval	UL approval / E63076

Technical data - mechanical design

Operating temperature	-10...+50 °C
Storing temperature	-20...+70 °C
Relative humidity	80 % non-condensing
Protection DIN EN 60529	IP 65 face with seal
Connection	Screw terminal connector
Core cross-section	1.5 mm ²
Operation / keypad	10 figure keypad with 5 function keys
Housing type	Housing for control panel installation
Dimensions W x H x L	72 x 72 x 108 mm
Cutout dimensions	68 x 68 mm
Installation depth	136.5 mm
Mounting	Front panel installation by clip frame
Weight approx.	330 g
Material	Polycarbonate black, UL 94V-0

Memory controllers

Manual format alignment

Display LCD two lines, interface RS485

N 240

Part number

N 240.

1	1	2	AX01
---	---	---	------

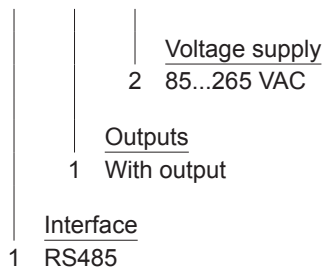

Description

The complete multicon system consisting of memory controller N 240 and several spindle position displays (SPAs) is a support in manual spindle positioning operations. A so-called format profile, what means complete position data of a whole format is once set at the SPA and can be filed in the controller under a certain name or number. Up to 100 format profiles with max. 32 spindle position values can be stored. Once filed in the controller, they can be recalled any time on request. The controller is passing the corresponding format position value to the respective spindle position display. The twin-line SPA display provides the operator not only with the current spindle position but also with the target to be set directly on site. Therefore, errors in parameterization are nearly eliminated by electronic processing.

Connection diagram

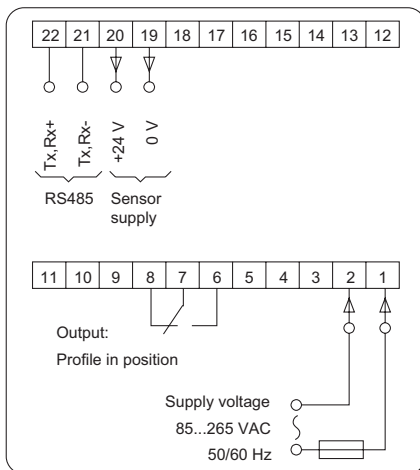

Dimensions

