



Operating Instructions

Electronic preselection counter in DIN rail housing NE230

Contents	Page
1 Safety instructions	2
2 Getting to know the counter	4
2.1 Components	4
2.2 Block diagram	4
3 Counter connecting	5
3.1 Connecting the power supply	6
3.2 Assignment signal output „relays contact“	6
3.3 Assignment signal input	7
3.4 Connecting examples	7
3.5 Connecting the encoder power supply	7
3.6 Connecting the interfaces	8
4 Operating level	8
4.1 Key functions	9
4.2 Operating functions	10
5 Programming level	10
5.1 Programming field 1	13
5.2 Programming field 2	14
5.3 Programming field 3	15
6 Operating mode	19
7 Counting modes (Input mode)	19
8 Output responses (Output mode)	20
9 Technical Data	21
9.1 Dimensions and cutout size	22
9.2 Error messages	22
9.3 Order designations	22



General Information

In the following you will find the explanations of the symbols used in this operating manual.

Explanation of symbols

- This symbol indicates activities to be carried out.
- This symbol indicates additional technical informations.



This symbol is located before texts to which particular attention is to be paid to ensure proper use of the product.



This symbol is located before texts that provide important additional information.

Italics

Important terms in the left text column are printed in italics to help you find information more quickly.

1 Safety Instructions

1.1 General information

The products has been developed and built in accordance with the recognized rules of technology. The units have left the manufacturing plant ready to operate and in safe condition. To keep the units in this condition, it is necessary that the units be installed and operated

- properly,
- in a safety and hazard-conscious manner,
- under observance of this operating manual and in particular of these safety precautions!

Make sure that the personnel has read and understood the operating manual, and in particular the "Safety Instructions" chapter. In addition to the operating manual, the generally applicable legal and other binding regulations for accident prevention and environmental protection must be observed and ensured.

1.2 Proper use

The application of the units consists of controlling and monitoring industrial processes in the metal, wood, plastics, paper, glass and textile industry etc.

The units may only be operated

- in the properly installed state and
- in accordance with the specifications of the technical data!



Operation not covered by the specified descriptions/parameters is improper and can lead to

- fatal injuries,
 - serious damage to health,
 - property damage or
 - damage to the units
- in conjunction with the systems/machines/processes to be controlled/monitored!



The overvoltages to which the units are subjected at the connection terminals must be limited to the value of the overvoltage category II (see Technical Data)!

The units may not be operated

- in hazardous areas,
- as medical units,
- in applications expressly named in EN 61010!



If the units are used to control/monitor machines or processes with which, as the result of a failure/malfunction or incorrect operation of the units

- a life-threatening danger,
 - health risks or
 - a danger of property or environmental damage
- could result, then appropriate safety precautions must be taken!
-

Do not open the housing of the units or make any changes to it!

Tampering with the units can have a negative affect on their operating safety, resulting in dangers!

Do not make repairs on the units! Return defective units to the manufacturer!

1.3 Installation/commissioning

In case of changes (including in the operating behavior) that impair safety, shut-down the units immediately.

Installation may only be carried out in accordance with the procedure described in Chapter 3 "Counter connecting".

During installation work on the units, the power supply must always be disconnected. Installation work may only be carried out by appropriately trained experts.

Max. voltage 250 V terminal - terminal, ground - terminal.

Following proper assembly and installation, the units are ready for operation. Following commissioning, familiarize yourself with the use of the units in Chapter 4 "Operating level".

1.4 Maintenance/repairs

Always disconnect the power supply of all units involved. Maintenance and repair work may only be carried out by appropriately trained experts.

If troubleshooting is unsuccessful, do not continue to use the units. Please contact the manufacturer in this case.



2 Getting to know the counter

2.1 Components

- 6-digit Preselection counter with 2 preselections
- 8-digit Totalizer
- 6-digit Time counter

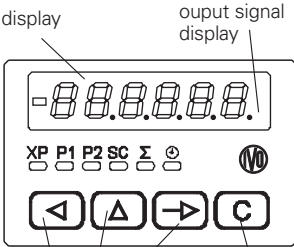

display
ouput signal display

decade selection
decade value

acknowledge key
reset key

Components / LED-display

- 7-segment LED-display
- XP Current counter status
P1 Preselection value 1
P2 Preselection value 2
SC Set value
Σ Totalizer
⊕ Time Counter

Control panel

- Selector key for function display, acknowledge key
- Setting key for decade selection / left
- Setting key for decade values / up
- Reset key

2.2 Block diagram

The block diagram shows the component parts of the counter, together with the terminals and connections.

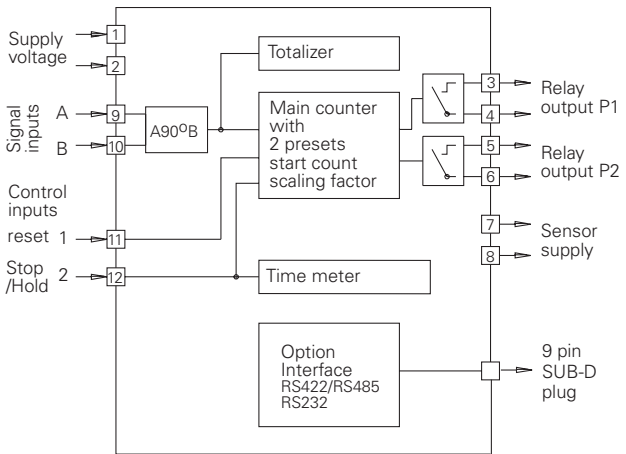



3 Connecting

This section describes the terminal assignment, accompanied by some examples of typical connections. Sections 3.1 to 3.6 contain specific instructions and technical data relating to the individual terminals.

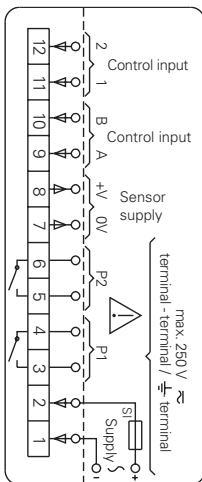

Assignment

Contact	Function
1	Supply voltage VAC/-VDC
2	Supply voltage VAC/+VDC
3	Relay output P1
4	Relay output P1
5	Relay output P2
6	Relay output P2
7	Sensor supply 0V
8	Sensor supply +V
9	Signal input track A
10	Signal input track B
11	Control input 1 (main counter Reset)
12	Control input 2 (main counter Stop)

Option: interface (SUB-D)

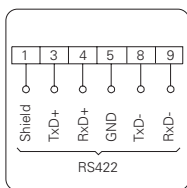
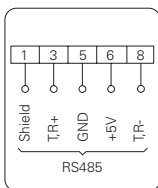
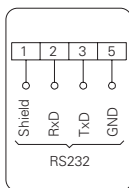

Contact	Function
1	Shield
3	T,R+
5	GND
6	+5V
8	T,R-
} Option RS485	
1	Shield
3	TxD+
4	RxD+
5	GND
8	TxD-
9	RxD-
} Option RS422	
1	Shield
2	RxD (out)
3	TxD (in)
5	GND
} Option RS232	



For protection against shock hazards as specified in VDE 0411 part 100, stranded conductors may only be connected using wire end ferrules with insulating caps. Terminals which are not assigned in the factory must not be otherwise assigned by the user. We recommend shielding all encoder connecting leads and earthing the shield at one end. Earthing at both ends is recommend to avoid RF interference or if equipotential bonding conductors are installed over long distances. Encoder connecting leads should not be laid in the same trunking as the main power supply cable and output contact leads.



3.1 Connecting the power supply

Three voltage ranges are available for the power supply.

AC voltage 85...265 VAC, 50 / 60 Hz

AC voltage 10...26 VAC, 50 / 60 Hz

DC voltage 10...30 VDC, 5 % residual ripple

AC voltage connection Connect AC at the contacts 1 and 2 according to the counter terminal diagram.

Power supply		Recommended external fusing
85...265 VAC	50/60 HZ	M 315 mA
10...26 VAC	50/60 HZ	M 400 mA

DC voltage connection Connect an interference-free power supply, i.e. do not use the parallel connection of the drive systems, contactors, solenoid valves, etc.

→ Connect the DC voltage in accordance with the counter wiring diagram.

Power supply	Recommended external fusing
10...30 VDC	M 400 mA



Fire protection: Operate instrument on the MAINS with external fuse recommended on the rating plate. EN 61010 specifies that 8 A / 150 VA (W) must never be exceeded in the event of a fault.

3.2 Assignment signal output „relay contact“

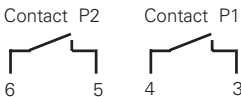

The signal outputs (Terminal 3, 4 and 5, 6) are no-potential relay contacts. The signal outputs can be assigned in accordance with the adjoining wiring diagram. The type of outputs, as momentary or latched signal, can be chosen in the programming lines 35 / 36. Their function, as normally open or closed, is selected in programming line 33.

Max. switching output	Max. switching voltage	Max. switching current
150 VA / 30 W	250 V	1 A



The user is responsible for ensuring that a switching load of 8 A/150 VA (W) is not exceeded in the event of a fault. Internal spark suppression by means of two zinc oxide varistors (275 V). The output relay of the instrument (1 relay or several) may only be disengaged in total 5 x per minute at the most. Admissible clicks according to Interference Suppression Standard EN 55011 EN 50081-2 for the industrial sector. In case of a higher switching rate, the operator must take care of interference suppression on the spot and under his own responsibility by observing the load to be switched.



3.3 Assignment signal input

Choice of PNP or NPN The contacts 9 to 12 are comparator signal inputs. They can be triggered either by PNP or NPN impulses. The input logic as well as the operating threshold are correspondingly chosen in programming line 28. The contacts 9 (Track A) and 10 (Track B) are counting inputs for a counting range between 3 Hz, 25 Hz or 10 kHz. The counting rate is determined in programming lines 26 and 27. The contacts 11 and 12 are 2 control inputs for Reset, Stop, Hold, Print, Keylock, etc. The function of these control inputs is selected in the programming lines 29 and 31.

Input resistance	Selectable operating threshold
Ca. 3 kOhm	3 V and 6 V

3.4 Connecting examples

Encoder

Contact assignment

Programming

Contact

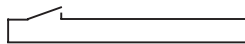

9 Track A
8 +18 V

Counting rate:
Line 26 to 1 = 25 Hz or
Line 26 to 2 = 3 Hz

Proximity switch PNP

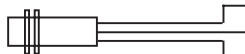

9 Track A
8 +18 V
7 0 V

Incremental encoder

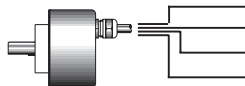

9 Track A
10 Track B
8 +18 V
7 0 V

Counting mode:
A 90° B (x1, x2, x4)
Line 25 to 3, 4, 5
Counting rate:
Line 26, 27 to 0 = 10 kHz

3.5 Connecting the encoder power supply



Connect encoder supply for rotary encoder, proximity switch, etc. to the contacts 7 and 8. Do not use the encoder supply to supply non-earthed inductive or capacitive loads.



The encoder power supply is not short-circuit proof.

Encoder supply With a power supply of 85...265 VAC = 18 VDC \pm 10% / 100 mA
With a power supply of 10...26 VAC = 9...34 VDC / 100 mA
With a power supply of 10...30 VDC = 7...28 VDC / 100 mA



3.6 Connecting the interfaces

The serial interface is capable of executing the following functions:

- Accessing data
- Programming parameters

Interface parameters are as follows:

- Data transmission rate (baud rate),
 - Parity bit,
 - Number of stop bits
 - Address used to access the control unit from a master computer.
- The interface parameters can be set in the programming mode (lines 51 to 54).

RS485 Semi-duplex transmission with the following characteristics:

- asymmetric
 - Two leads
 - Multi-point connection - 1 transmitter and 32 receivers
 - Max. data transmission distance: 1500 m
- Assign contacts 3 (T, R+), 8 (T, R-) accordingly.

RS422 Full-duplex transmission with the following characteristics:

- Symmetrical
 - Four leads
 - Multi-point connection - 1 transmitter and 32 receivers
 - Max. data transmission distance: 1500 m
- Assign contacts 3 (TxD+), 8 (TxD-), 4 (RxD+), 9 (RxD-) accordingly.

RS232 Full-duplex transmission with the following characteristics:

- Asymmetric
 - Three leads
 - Point-to-Point connection - 1 transmitter and 1 receiver
 - Max. data transmission distance: 30 m
- Assign contacts 3 (TxD), 2 (RxD), 5 (GND) accordingly.



4 Operating level

The device consists of an operator level and a programming level. The operation and use of the counter are described in this section.

- As soon as the power supply has been switched on, the counter is automatically set to the operating mode.

- Operating mode* In the operating mode:
- the current main counter XP status can be read and reset;
 - the set preselection values P1 and P2 can be read off and changed if necessary;
 - the set setting value SC can be read off and reset if necessary;
 - the totalizer Σ can be read off and reset if necessary;
 - the time counter Θ can be read off and reset if necessary;
 - the scaling factor SF can be read off and reset if necessary;
- It is possible to disable all operator parameters on the programming level (Lines 11-17).



4.1 Key functions

Parameter reading The key  allows to switch to the next operation parameter. For quick sweep, keep the key depressed.

Resetting of counts

1. Display count of respective parameter.
2. Press the  key.

Parameter reading

1. Display parameter.
2. Press the  key and select required decade; chosen decade position blinks.
3. Press the  key and enter required value.
To set further decades, repeat steps 2 and 3.
4. Confirm the parameter entered with  .
Should no confirmation be given within 15 s, then the previous setting will remain valid.



4.2 Operating functions

Current counter status

After the counter is switched on or when selected by pressing the key, the current counter status can be read off. The "XP" LED lights up.

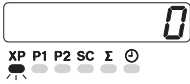

To read Read counter status "XP".

Reset Press the key.

Preselection P1

To read Press the key. The preselection value P1 can be read off in the display. LED "P1" flashes.

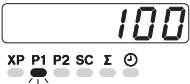

To change Enter preselection P1 with keys and .
Sign possible following release in line 38.

Press the key.

Preselection P2

To read Press the key. The preselection value P2 can be read off in the display. LED "P2" flashes.



To change Enter preselection P2 with keys and .
Sign possible following release in line 38.

Press the key.

Set value SC

To read Press the key. The current setting value SC can be read off in the display. LED "P1" flashes.

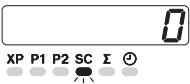

To change Enter setting value SC with keys and .
Sign possible following release in line 38.

Press the key.

Totalizer Σ

To read Press the key. The current total value can be read off in the display. LED " Σ " flashes.

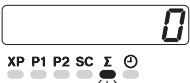

If the value 999999 is exceeded, its display will be shown in two steps. First step: Display of the first 6 digits. Second step, marked by „H“: Display of 7th and 8th digits. Display of each value for approx. 3 seconds.

Reset Press the key.



Time counter

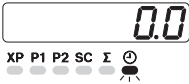

To read Press the key. The operating hours can be read off in the display. LED " " flashes.

Reset Press the key.

Scaling factor SF



To read Press the key.
The current scaling factor SF can be read off in the display.

To change Enter scaling factor SF via and .
Press the key.

The scaling factor allows the display of fractions or multiples of the counting pulses.

Setting range: 0.0001 to 9999.99. Setting ex factory 1.0000

Example In the case of a length measurement by means of encoder and cyclometer, where the circumference of the cyclometer measures 200 mm and the encoder supplies 500 pulses per revolution, the measurement is to be displayed in mm. The scaling factor is calculated as follows:

$$\text{Scaling factor} = \frac{\text{Circumference}}{\text{Pulses}} = \frac{200}{500} = 0.4000$$



By pushing again, the current counter status is re-displayed.



5 Programing level

Operating parameters are set in the programming mode, which is subdivided into three programming segments. Access is protected by a 4-digit code.

- Programing segment 1* Here it is possible to select and modify all operation parameters. The operation parameters that are disabled for the operator are also displayed.
- Programing segment 2* The individual operation parameters for operator access are disabled or enabled here.
- Programing segment 3* All functions and values as well as interface parameters conditioned by the machinery are programmed here.

Key functions

To switch on programming Press key and key simultaneously. „Code“ appears in the display.



No code is set in the factory settings, and therefore this code request can be skipped by pressing the key. The code is set in programming line 40. After a code has been set, it is only possible to switch to the programming level by entering the correct code.

To enter code Enter the code with the keys and . Press the key to acknowledge the entry. The system switches from the operator level into the programming level.

Incorrect code If an incorrect code is entered, „Error“ appears in the display as long as the key is pressed. After 15 s the system automatically switches back to the operator level.

Correct code unknown If the correct code is not known, please return the counter to the supplier or reset it to the factory setting.

Selecting programming lines Select the corresponding programming lines with the key. The corresponding line number is displayed. Press and hold the key to scroll.

Switching back programming line It is possible to jump back within the programming lines by pressing and holding the key.

Changing operating parameters Select the decade to be changed with the key. The selected decade flashes. Enter the value by pressing the key. Press the key to acknowledge.

Exiting programming Programming can be ended at any time by pressing the keys and (hold for 2 seconds).

Resetting to factory setting Switch on the device and simultaneously press the keys and . All values already programmed will be reset to the factory setting. „ClrPro“ appears in the display.



5.1 Programming field 1

All operating parameters can be selected and changed here. The operating parameters blocked for the operator are also displayed.

Line 1  **PC - Current counter status**



Line 2  **P1 - Preselection value 1**



Line 3  **P2 - Preselection value 2**



Line 4  **SC - Set value**



Line 5  **Σ - Totalizer**



Line 6  **⌚ - Time counter**

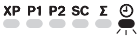

Line 7  **SF - Scaling factor**



At the conclusion of the first programming segment, a broken line appears in the display.

Advance to Programming field 2 with the  key.



5.2 Programing field 2

The individual operation parameters for operator access are disabled or enabled here. **StAt** appears in the display.

- The current status value appears in the display. The respective LED for the selected line XP, P1, P2, SC, S or Σ flashes (There is no LED for the SF scaling factor).

Significance of status numbers

- 0 free access** It is possible to select, read and modify the operation parameter on the operator level.
- 1 display only** It is possible to select and read the operation parameter on the operator level.
- 2 disabled** It is impossible to select the operation parameter on the operator level. Its corresponding function is however sustained.



Default settings are always printed with * .

To change status Input the appropriate status number via the keys and . The changed status will automatically be stored when the next programming line is selected with key .

Line 11

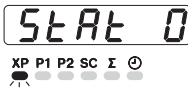

PC - Main counter

- 0 * free access
- 1 display only
- 2 disabled

Line 12



P1 - Preset value 1

- 0 * free access
- 1 display only
- 2 disabled

Line 13

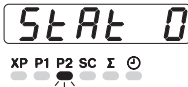

P2 - Preset value 2

- 0 * free access
- 1 display only
- 2 disabled

Line 14



SC - Set value

- 0 * free access
- 1 display only
- 2 disabled

Line 15

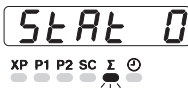

Σ - Totalizer

- 0 * free access
- 1 display only
- 2 disabled



Line 16



- ⊕ - Totalizer**
 0 * free access
 1 display only
 2 disabled

Line 17



- SF - Scaling factor**
 0 * free access
 1 display only
 2 disabled



A broken line will appear in the display, signifying the completion of the second programming segment.

5.3 Programing field 3

The machine-dependent functions and values, as well as the interface parameters are programmed here.



Default settings are always printed with * .

Line 22



- Operating mode Main counter**
 0 * Step preset
 1 Main preset
 2 Parallel comparsion
 3 P1 - Self-adjusting preset

Line 24



- Decimal point for XP, P1, P2, SC, Σ**
 0 * no decimal point
 1 00000.0
 2 0000.00
 3 000.000
 4 00.0000

Line 25



- Counting mode**
 0 * Track A UP/Down signal on track B
 1 Differential counting track A adding track B subtracting (A-B)
 2 Totalizing, tracks A and B adding (A+B)
 3 Track A 90° track B single evaluation
 4 Track A 90° track B twofold evaluation
 5 Track A 90° track B fourfold evaluation



With the counting mode "Track A 90° track B" the frequency of track. A and B (line 26 and 27) is set to 10 kHz.

Line 26



- Frequency Main counter track A**
 0 * 10 kHz
 1 25 Hz
 2 3 Hz



Line 27

27 0

Frequency Main counter track B

- 0 * 10 kHz
- 1 25 Hz
- 2 3 Hz

Line 28

28 0

Input logic and operating threshold of signal input

- 0 * PNP logic, operating threshold 6 V
- 1 NPN logic, operating threshold 6 V
- 2 PNP logic, operating threshold 3 V
- 3 NPN logic, operating threshold 3 V

Line 29

29 0

Reset main counter (control input 1, connection 11)

- 0 * Autom. reset and ext. static
- 1 Autom. reset and ext. edge-active
- 2 External static
- 3 External edge-active
- 4 External with "Start function",
Relays are activated by control signal and deactivated again when preselection is reached.

Line 31

31 0

Function control input 2 (connection 12)

- 0 * Stop
- 1 Hold
- 2 Keylock
- 3 Operating hours counter counts/stops, counts as long as signal is active
- 4 Actual value correction
- 5 Print (only with interface option)

Line 33

33 0

Output logic

- 0 * Both outputs as normally open
- 1 P1 normally closed, P2 normally open
- 2 P1 normally open, P2 normally closed
- 3 Both outputs as normally closed

Line 35

35 0

Output time P1

- 0,0 Minimum signal duration
- 0,25 * Default
- 99,99 Maximum signal duration
- LAtCH = Latched signal (by pressing the C-key)

Line 36

36 t2

Output time P2

- 0,0 Minimum signal duration
- 0,25 * Default
- 99,99 Maximum signal duration
- LAtCH = Latched signal (by pressing the C-key)

Line 37

37 0

Application of preselections P1, P2, SC

- 0 * Immediately active
- 1 With reset



- Line 38** 38 0 **Setting range P1, P2 and SC**
 0 * Only in positive counting range
 1 In positive and negative counting range
- Line 40** 40 Cod **Code settings**
 0 * Code not active
 Max. 9,999
- Line 41** 41 0 **Function of secondary counter**
 0 * As total sum counter (counting parallel to main counter)
 1 As batch counter (counting automatically when P2 is reached)
- Line 42** 42 1 **Multiplication of secondary counter (only if line 41 = 1)**
 1 * Default
 Max. 999
- Line 43** 43 0 **Actual value correction (only if line 31 = 4)**
 0 * No correction value
 Max. 999,999
- Line 44** 44 0 **Display following a power failure**
 0 * no power failure display
 1 Power failure display, display flashes (cancel with key).

- Line 51** 51 0 **Baud rate**
 0 * 4800 Baud
 1 2400 Baud
 2 1200 Baud
 3 600 Baud
- Line 52** 52 0 **Parity**
 0 * Even Parity
 1 Odd Parity
 2 No Parity
- Line 53** 53 0 **Stop bits**
 0 * 1 Stop bit
 1 2 Stop bits
- Line 54** 54 0 **Adresse**
 0 * from
 99 to

**Line 55**
Assignment of output values via interface (line 31 = 5)

- 0 * Display value
- 1 XP
- 2 P1
- 3 P2
- 4 SC
- 5 Σ
- 6 \oplus
- 7 SF

Line 56
RS422: Control of connections TxD+ or TxD

- 0 * Switched in transmission direction during transmission,
in reception direction during reception
- 1 Always in transmission direction

The dash line indicates the end of the third programming field.

As soon as is pushed again, the instrument will automatically return to the operator level. Programming can, however, be shut down on any line by simultaneously pushing and (keeping the keys depressed for ca. 2 seconds).



6 Operating modes

The operating modes are described below.

Step preset The preselections are always handled in the sequence P1, P2 after each reset. When the first preselection P1 is reached, there is no automatic reset. When the second preselection P2 is reached, the count may be reset either automatically or through an external signal. Please observe programming line 29 to this effect. An external or manual reset is possible at any time.

Main preselection The preselections are always handled in the sequence P1, P2 after each reset. When the first preselection P1 is reached, there is one automatic reset. When the second preselection P2 is reached, the count may be reset either automatically or through an external signal. Please observe programming line 29 to this effect. An external or manual reset is possible at any time.

Parallel comparison When the preselections P1 and P2 are reached or exceeded, the outputs switch and remain active until the count is equal to or higher than the corresponding preselection.

P1 trailed preselection Signal output P1 always switches according to Preselection P1 prior to Preselection P2 (Out P1 = P2-P1). This means that, when changing the Preselection P2, Preselection P1 will automatically be „trailed“. This mode is well suited, for example, for switching between rapid and creeping speed in the case of length measurement applications.

7 Counting modes (input mode)

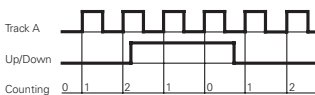

Counting input Track A, possibly set to Up/Down signal on Track B
Programming line 25 to digit 0.

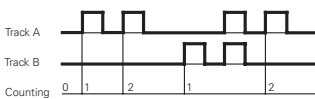

Differential counting Track A adding and Track B subtracting (A-B)
Signal duration and particular time at choice.
Programming line 25 to digit 1.

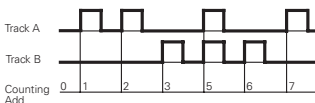

Totalling Track A adding and Track B adding (A+B)
Programming line 25 to digit 2.

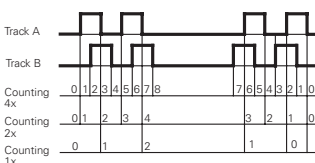



Up and down count with two counting signals by 90° out of phase
The counting direction is automatically recognized on the basis of the 90° leading or trailing phase shift. The internal phase discriminator does the evaluation. Single, double or quadruple evaluation is possible. Programming line 25 to digit 3, 4 or 5.



8 Output responses (output mode)

The behavior of the signal outputs is defined by the following settings under the programming field 3:

Operating mode, reset mode, take-over of preselections, output logic and output time P1, P2 as momentary  or latched signal . The following diagrams illustrate some examples:

Programming

Operating mode:
Line 22 to 0 = Progressive selection
Reset mode: Line 29 to 2
without automatic reset
Output time P1, P2:
Line 35, 36 to pulse or duration

adding

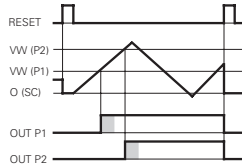

subtracting

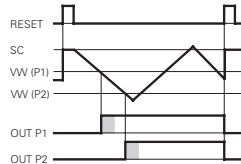

Operating mode:
Line 22 to 0 = Progressive selection
Reset mode: Line 29 to 0
with automatic reset

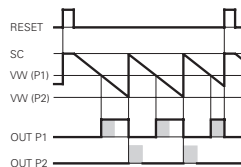
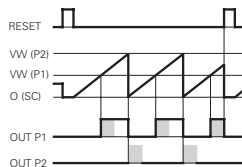

Operating mode:
Line 22 to 1 = Main preselection
Reset mode: Line 29 to 0
with automatic reset

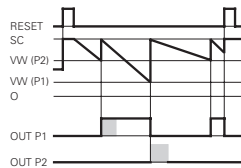
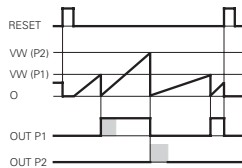

Operating mode:
Line 22 to 2 = Parallel comparison
Reset mode: Line 29 to 2
with automatic reset

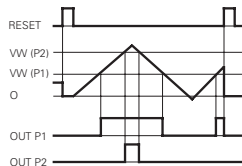

Operating mode:
Line 22 to 3 = Schleppevorwahl
VW (P1) corresponds to the interval
between P1 and P2. When P2 is
changed, P1 is trailed.

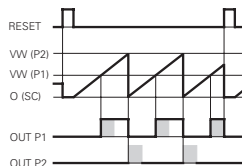

Operating mode:
Line 22 to 0 = Trailing preselection
Reset mode: Line 29 to 4
without automatic reset, external
RESET with Start function. OUT P1
and OUT P2 are activated via the
external RESET and deactivated
when the preselection is reached.

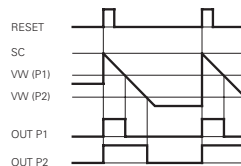
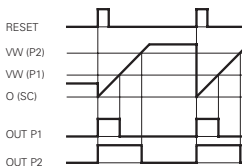



9 Technical Data

Display	7-segment LED-display 6-digit, red, with suppression of leading zero - minus sign for negative values
Digit size	7.6 mm
Supply voltage	85...265 VAC (50 / 60 Hz) 10...26 VAC (50 / 60 Hz) 10...30 VDC, 5 % RW
Power consumption	5 VA, 4 W
Encoder supply	85...265 VAC = 18 VDC \pm 10 % / 100 mA 10...26 VAC = 9...34 VDC / 100 mA 10...30 VDC = 7...28 VDC / 100 mA
Signal inputs	Comparator inputs, PNP, NPN, Voltage level 4...40 V, Input resistance ca. 3 kOhm
Input counting rate	To be programmed to 3 Hz, 25 Hz or 10 kHz
Control inputs	2 control inputs for Reset, Stop, Hold, Correction, Print usw.
Signal outputs	To be programmed as momentary or latched signals Impulse time to be programmed from 0.01 to 99.99 s (Tolerance +0,01s)
Relay signal outputs	2 floating relays to be programmed as normally closed or normally open. Internal spark suppression Max. switching voltage 250 VAC / 110 VDC, Max. switching power 1 A Max. switching capacity 150 VAC / 30 W
Data storage	> 10 years via EEPROM
Operating modes	Step Preselection, Main Preselection, Parallel Comparison, Trailing Preselection Programmable additive or subtractive
Handling, keypad	Front membrane with short-stroke keys
Front measures	DIN-casing 86 x 70 mm
Mounting	On DIN rail EN 50022
Weight	Ca. 180 g
Connections	Plug-in screw terminals; Grid 5 mm / SUB-D socket, 9-pin
Core cross-section	Max. 1.5 mm
Casing material	
Upper section	Polycarbonate, UL 94V-1
Lower section	Polyphenylene oxide UL 94V-0
Material of front membrane	Polyester
Ambient temperature	0...+50 °C
Storage temperature	-20...+70 °C
Humidity	Max. relative Feuchte 80 %, bei 25 °C nicht betauend
Protection	Frontseite IP 50 nach DIN VDE 0470-1
General rating	EN 61010 Part 1 - Protection class II - Overvoltage protection category II - Contamination factor 2
Interference immunity	EN 61000-6-2
Emitted interference	EN 50081-1



9.1 Dimensions

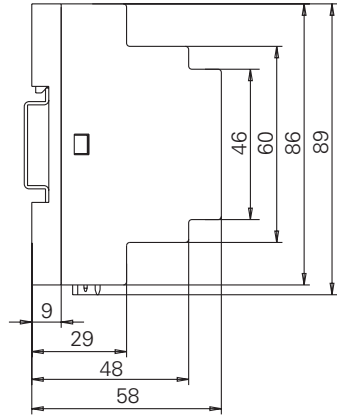
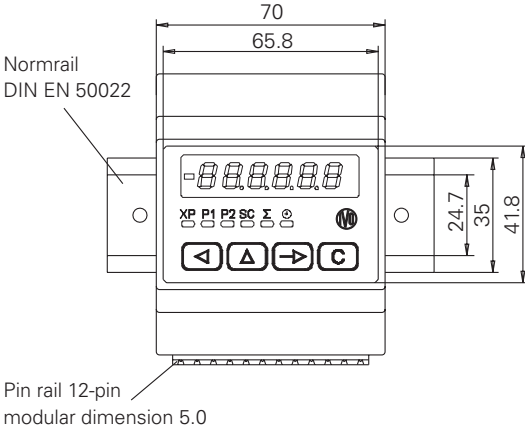

9.2 Error messages

Err 1 and Err 2: Fault must be rectified by the factory.

Err 6: Excessively fast sequences, i.e. inadequate intervals between presets at high counting frequency.

- Error messages Err 6 can be cleared with the **C** key.

9.3 Order designation

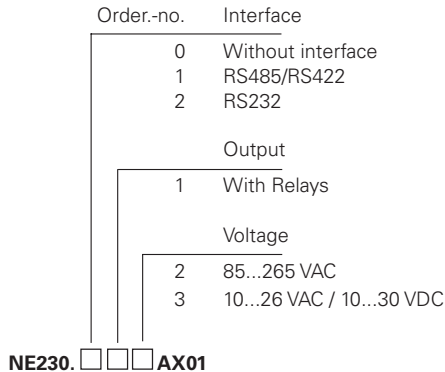





IVO GmbH & Co. KG

P.O. Box 3360

D-78022 Villingen-Schwenningen

Telefon +49 (0)7720 942-0

Telefax +49 (0)7720 942-900

e-mail: info@ivo.de

www.ivo.de

A Member of the Baumer Group

Printed in Germany